

GatekeeperLtd.
www.gatekeeperltd.com



YG200 SWING GATE OPENER
OWNER'S MANUAL

©2005

Gatekeeper Ltd.

P.O. Box 752

Laceys Spring, AL 35754

<http://www.gatekeeperltd.com>

OUTLINE

1. Safety Precautions
2. Features
3. Specifications
4. Necessary Tools
5. Site Preparation
6. Mechanical Installation
7. Electrical Installation
8. Operation
9. Trouble Shooting
10. Warranty

IMPORTANT SAFETY INFORMATION



Installing the YG200 Gate Opener requires the installation of standard 110V electrical wiring. This work should only be performed by a trained technician. Miswiring could cause personal injury or DEATH. To prevent the risk of electrocution, be sure to turn off all power to the YG200 until installation is complete. Read the the entire user's manual before beginning installation, and carefully obey the following instructions:

- The Gate Opener should be installed by a qualified technician. Otherwise, serious personal injury or property damage may occur.
- Before installation, all the locks of the gate should be unlocked.
- The auto-reverse function must be checked during installation to ensure that the gate can auto-reverse in the event of obstruction.
- This auto-reverse function should be regularly inspected and adjusted, if necessary.
- When opening or closing the gate, do not attempt to walk or drive through the gate. Do not touch the gate while in operation.
- Children should not be allowed to play near or operate automatic gates.
- The maximum force that the gate opener can provide is 1500N.
- An electric lock is provided for installation for gate lengths greater than 5 feet (1.5 meters).
- **IMPORTANT:** Before installing, verify that the force adjust knobs inside the control box for each motor are in the low position, and only advance it towards additional force as required. *See section Adjustment of the Auto-Reverse Function*
- This unit uses a current feedback system to stop. Do not operate the opener without a solid stop block in place. This could cause injury, damage to the opener or other personal property.
- Do not install the gate too close to the limit of travel; install the stop block with at least three inches margin.
- The automatic gate opener must be grounded.
- Do not attempt to go through the gate while it is still in motion.
- This operator is intended for vehicular use only.
- Be careful when in close proximity to moving parts where hands or fingers could be pinched.
- Additional safety equipment such as photoelectric sensors, safety edges, roller guards and warning signs must be installed to prevent injury.
- Do not allow control devices to be placed so that a person can access them by reaching through the gate.
- In the event of power failure, an emergency release key allows you to operate the gate manually.
- The opener should be switched off before repairing it or opening its cover.
- Please erase and reset the code after installing the opener.

Class I: A vehicular gate opener (or system) intended solely for use in a single-family home, or an associated garage or parking area.

ADDITIONAL FEATURES

- Supports gate leafs up to 440 lbs or 8.2 feet
- Keypad interface.
- Single button interface.
- Three position switch interface.
- Infrared safety beam interface.
- Supports up to 25 RF remotes, 2 included.
- User programmable and user erasable remote codes.
- RF rolling code technology prevents thieves from guessing your remote code.
- Auto-close feature is available for this opener.
- Solid steel lock.
- Push to open or pull to open configurable
- Opening and closing position is automatically learned by the operator, no need to program it.
- Aluminum and cast metal housing.
- For your safety, the YG-200 will stop and reverse if it encounters an obstruction on opening and stop when it encounters an obstruction on closing, as required by UL-325 safety standards.
- Manual key release design for emergency purposes
- Self-locking at any position

Specifications

| | |
|--|------------------------------------|
| Power Supply | AC 110V±10%V, 60Hz |
| Motor Speed | 1680 rpm |
| Motor Output | AC110V, 150W |
| Electronic lock Output | DC12V 2A |
| Relay coil voltage | DC12V |
| MCU voltage | DC5V |
| Remote control range: | 30m, Hopping Code |
| Control Box Weight | 2Kg |
| Control Box Dimension: | 276 mm (L) x 211 mm (W) x 112mm(H) |
| Environment temperature | 10°C~+40°C |
| Auto Close Timer: | 30 ± 3 seconds |
| Opening Time | <26 seconds |
| Working Angle of Gate | 90° or 105° |
| Max. Gate Section Weight | 440 lbs. (200kg) |
| Max. Gate Section Width | 8.2 feet (2.5 meters) |
| Duty Cycle | 25% |
| Noise | <65dB(A) |
| Emergency Release Key in Case of Power Failure | |

Class I: A vehicular gate opener (or system) intended solely for use in a single-family home, or an associated garage or parking area.

Necessary Tools and Equipment

The following tools may be necessary to install the YG-200 opener. You will need standard and Phillips screw drivers, an electric drill, wire cutters and a wire stripper, a socket set, and possibly access to a welder if your installation cannot use the supplied brackets. If the brackets shipped do not fit your gate because of the dimensions of your gate, you may also need equipment to cut and grind metal parts. In some rare cases you may have to fabricate brackets for your application or notch a column in order to obtain the necessary set back.

Site Preparation

Before you begin the opener installation, the gate should be mounted to the mounting posts and swinging freely, there should be little resistance in the swing of the gate. The gate and post must be suitable for being automated. Check that the structure is sufficiently strong and rigid, and that its dimensions and weights conform to those listed in the specifications table of this document. Make sure that the gate is plumb and level. The fence posts must be mounted in concrete. Since both motors must be powered, a set of wires from the control box to both motors will be required. Therefore it is necessary to dig a shallow trench across the driveway. If the driveway is paved this will require a masonry saw and chisel. The YG-200 is powered by 110V/60Hz AC power, therefore if you have not already done so; wire a waterproof outlet near the gate following proper safety standards for your area. If you are not experienced with this type of wiring or if your area requires it, hire a professional electrician to perform this as well as wire in the YG-200 in the electrical section. The YG-200 requires at least a 10A service. Make sure your electrician takes into account the voltage drop involved in running many feet of wire to your installation location. If an insufficient gauge of wire is used, there will be insufficient power at the site to operate the opener. Once the gate is mounted adequately, electrical power is available, and a trench for the control motors is dug, you are ready to proceed.

Parts List

| | | | |
|----|--------------------|----|-------------------|
| 1 | Hood pipe | 22 | 24T ring gear |
| 2 | End joint | 23 | Locating shield |
| 3 | Pin 10x40 | 24 | Motor |
| 4 | Steel tube | 25 | Capacitor bracket |
| 5 | Small support ring | 26 | Capacitor |
| 6 | Right housing | 27 | Wiring base |
| 7 | Screw M5x20 | 28 | Wiring terminal |
| 7A | Locknut | 29 | Screw M4x8 |
| 8 | Screw shaft | 30 | Wiring cover |
| 9 | Connect socket | 31 | Tapping screw |
| 9A | Split ring | 32 | Joint block |
| 10 | Tapping screw | 33 | Axle pin |
| 11 | Outer tube | 34 | Earth wire |
| 12 | Large support ring | 35 | Release key |
| 13 | Bearing 6004 | 36 | Lock |
| 14 | Pin 8x35 | 37 | Seal 17X2.65 |
| 15 | 27T ring gear | 38 | Upper cover |
| 16 | Planetary gear | 39 | Screw 4.2x9.5 |
| 17 | Central gear | 40 | Waterproof seal |
| 18 | Pin 4x20 | 41 | Hexagonal nut |
| 19 | Seal 13.2x2.65 | 42 | Light housing |
| 20 | Square gasket | 43 | Waterproof seal |
| 21 | Spring | | |

Parts Diagram

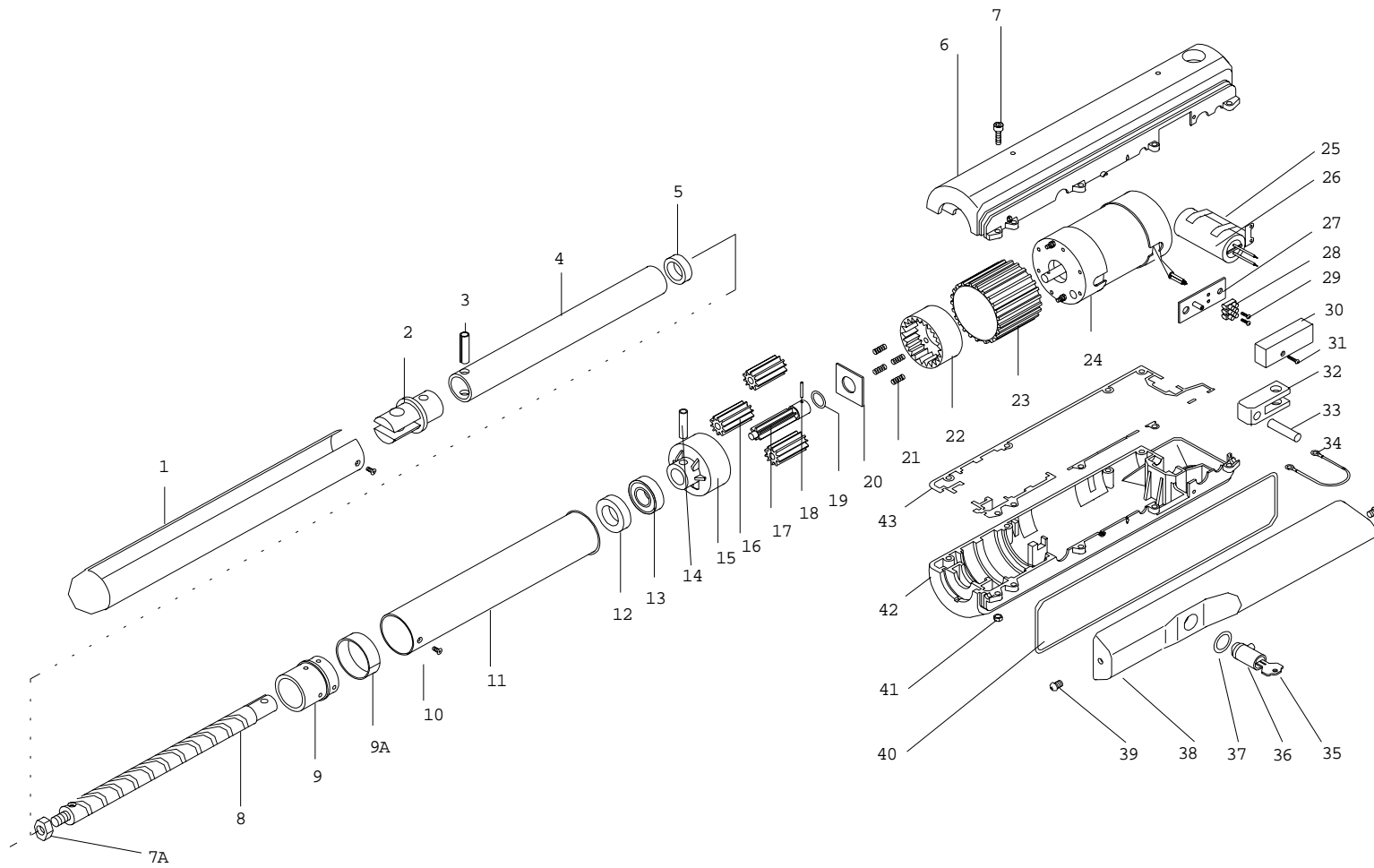

Mechanical Installation

Begin with both openers unlocked. Next identify if this will be a “push to open” or a “pull to open” installation. In either configuration, the gate is mounted on one face of the mounting post, and the opener is mounted on the face 90 degrees from it. Below are schematics of both “push to open” and “pull to open” configurations.

Fig. 1

Push to Open

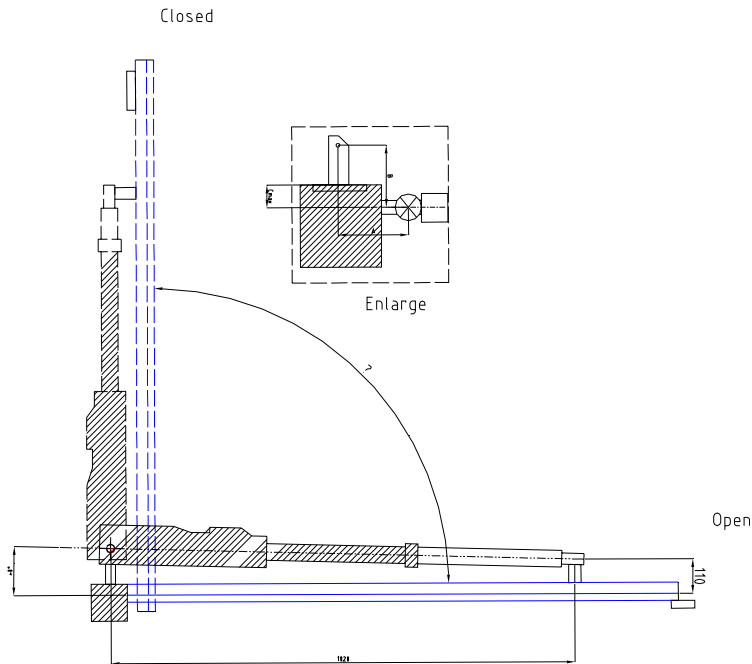
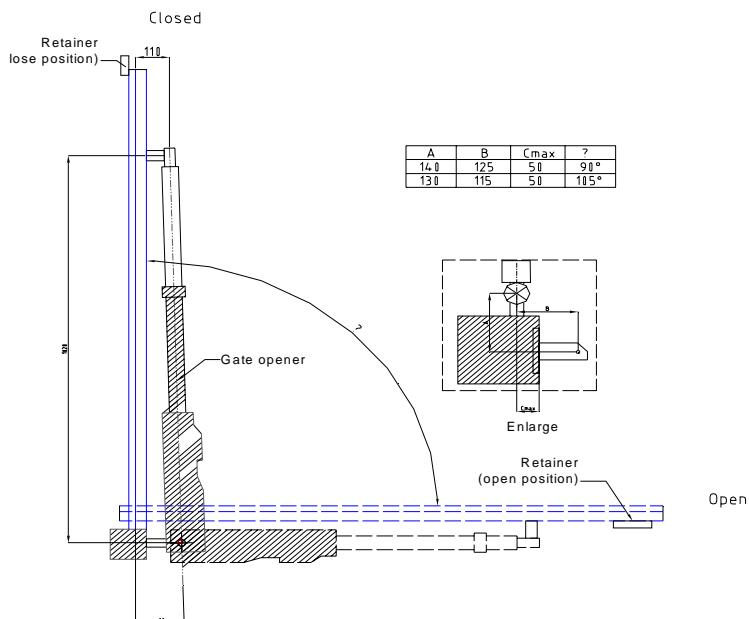

Fig. 2

Pull to Open



The installation should meet the specifications shown in figure 3. See Fig. 3.

Fig. 3

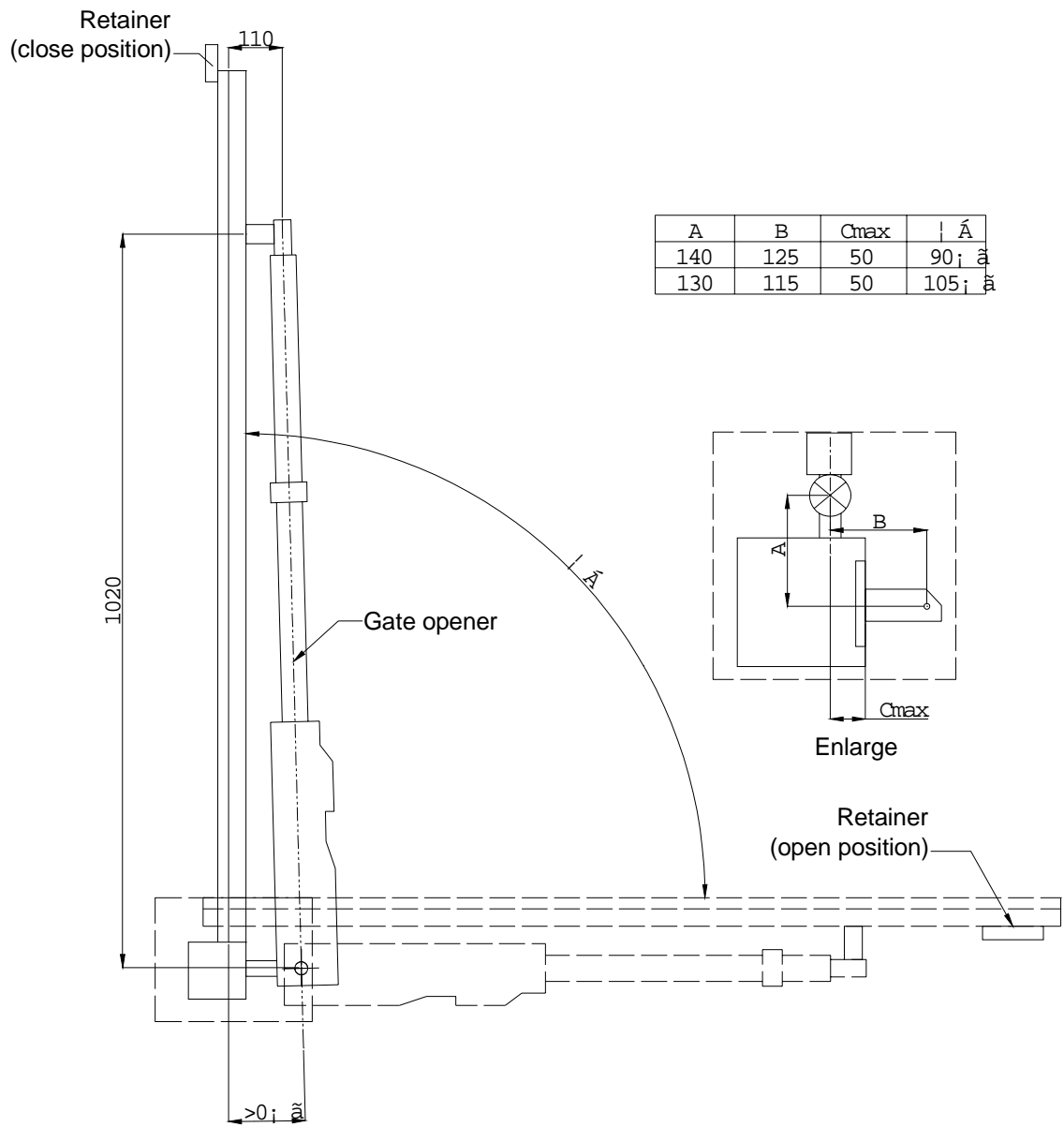

Main Structure

Fig. 4

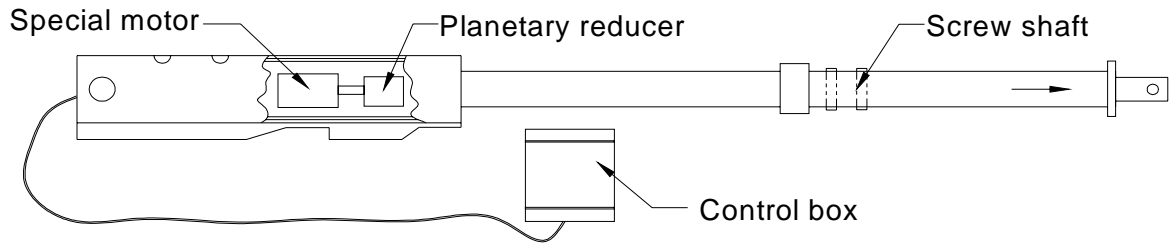

The installation height range is 1.18 – 3.15 inches (300 – 800mm). See Fig. 5. If the opener is mounted at a height above the specified range, and the gate is not sturdy enough, then it may result in bending or damage to the gate and or gate opener.

Fig. 5

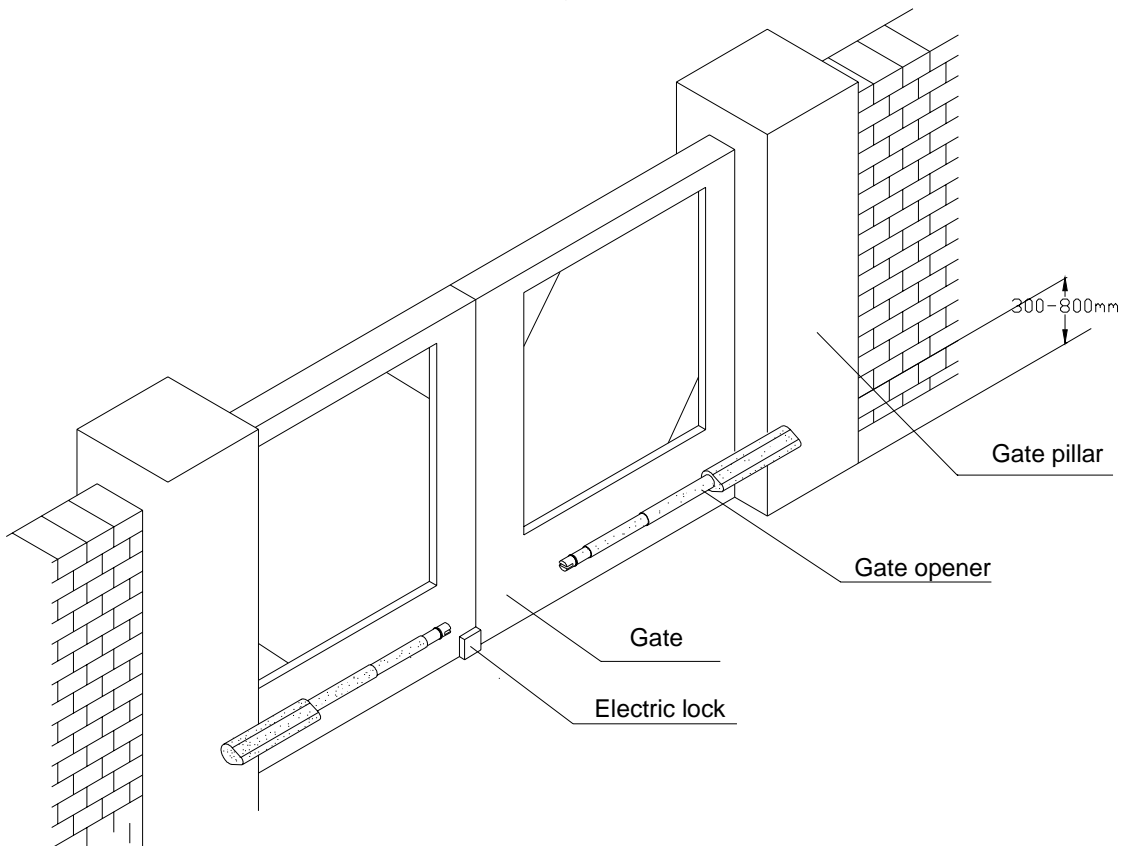

Gate Geometry

In order to obtain the desired opening angle, proper gate geometry is essential. This is also sometimes called setback. The opener must be able to swing from the closed position to the open position (touching the stop block) while not extending to within 3 inches of its maximum travel. This may involve notching the column, which is cutting into the column in order to bring the opener nearer to the gate hinge. Another alternative to notching the column is manipulating the shape and length of the brackets used to mount the gate to the post, the actuator to the post, and the actuator to the gate. These brackets are labeled A, B, and D, respectively. With these bracket lengths known, the opening angle and G, the position along the gate which the D bracket is welded can be calculated. Of course many installers accomplish this by trial and error, but it can be calculated directly, and an online calculator is available on the Gatekeeper site at:

www.gatekeeperltd.com/calc/calcgate.php

Most users will not be able to vary the size of the bracket A, the bracket holding the gate to the post. It is also relatively impractical to vary the bracket D, the bracket which holds the actuator to the gate. Therefore the most common and straightforward way to proceed is to vary the value of B until the calculator provides the proper value for the opening angle. Always verify that the required 3 inches of margin mentioned above is preserved when checking these measurements.

Positive Stop Block Installation

The YG-200 Automatic Gate Opener uses a current feedback system to detect its stopping / reversing point. The control box supplies an electrical current to the actuator motors to move the gate. As resistance increases, for instance hitting an obstacle or the stop block, the current required to continue operating the actuator motor increases. The control box constantly compares the required current with the position of the force adjustment knob. If the required current is greater than the position of the force adjustment knob, then the opener will stop. If the actuator has not traveled a significant portion of its available travel during closing, when it detects this high current condition, it will sound the alarm and perform an emergency stop and auto reverse. If this condition is detected during opening instead of closing, it will perform an emergency stop. **If an emergency stop condition occurs, terminate power to the unit, use the keys to unlock both actuators, and move them to the closed (actuators retracted) position before re-enabling power to the unit. Failure to do so could cause damage to the opener or gate.**

Therefore, the YG-200 absolutely requires a solid stop block. The stop block (supplied in the YG-200 kit) should be placed such that it stops the actuator arm at least 3 inches before it reaches its maximum travel. This margin is required to prevent the actuator arm from over-extending before the control box can shut down power to it. After mounting the actuator arm, with the key unlocked, verify that it stops at the proper position.

The gate geometry must be manipulated until the gate can be moved from the closed to the open position with the desired opening angle and without reaching within 3 inches from the end of travel before hitting the stop block. You are not ready to proceed to powering the actuator arms or mounting the control box until this step is accomplished!

Front and Rear Parts of Gate Opener

To install the rear part of the gate opener, insert shoulder screw and spacer, then tighten with the nut. See Fig. 6.

Fig. 6

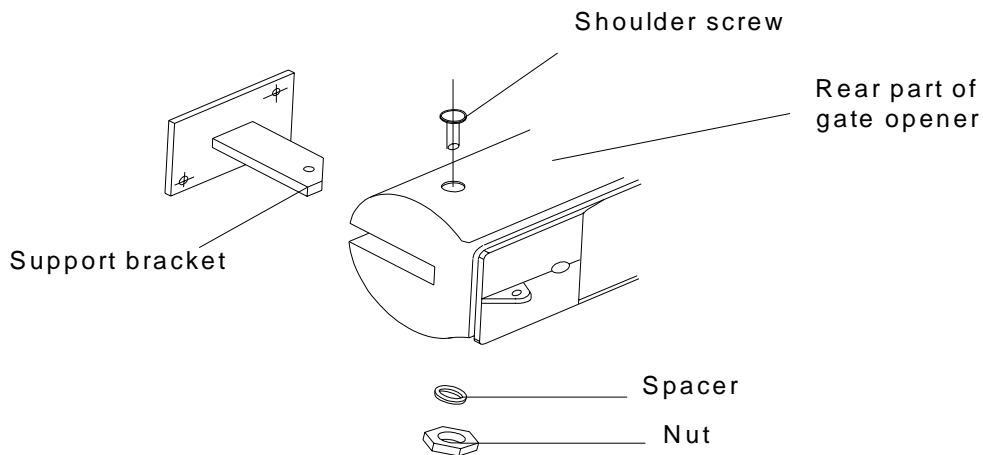

To install the front part, fit the hole in the front part with the hole in the supporting plate, and push the axle pin into the holes (using hands or a hammer), and finally fit the retainer clip. See Fig. 7.

Fig. 7

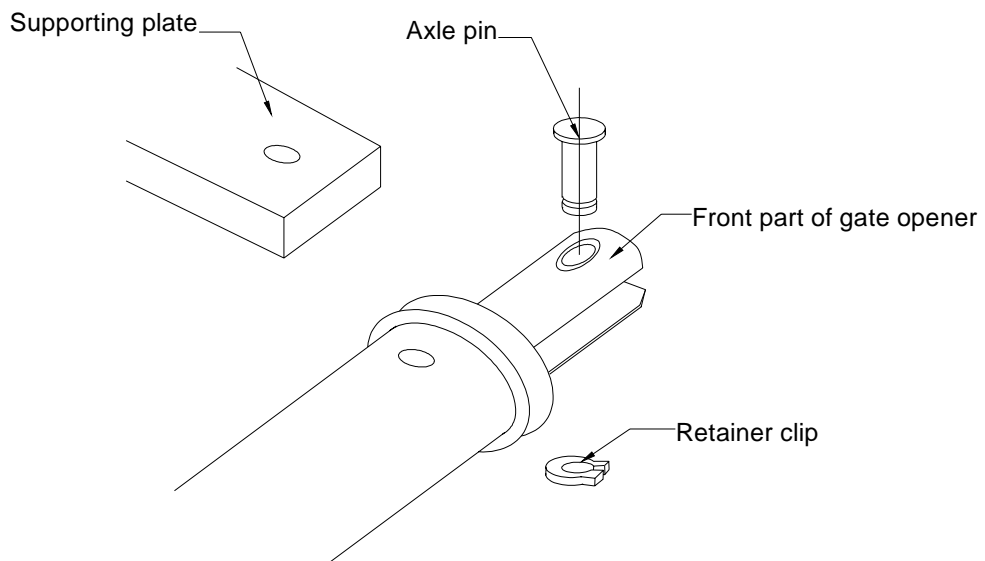

Wiring of the gate actuators

Screw off the two stainless tapping screws, and then remove the cover and wiring as shown in Fig. 8. **WARNING: Follow the wiring diagram precisely. Failure to do so could cause damage to the gate opener controller. Gauge 16-3 wire is sufficient for wiring the gate motors.**

Fig. 8

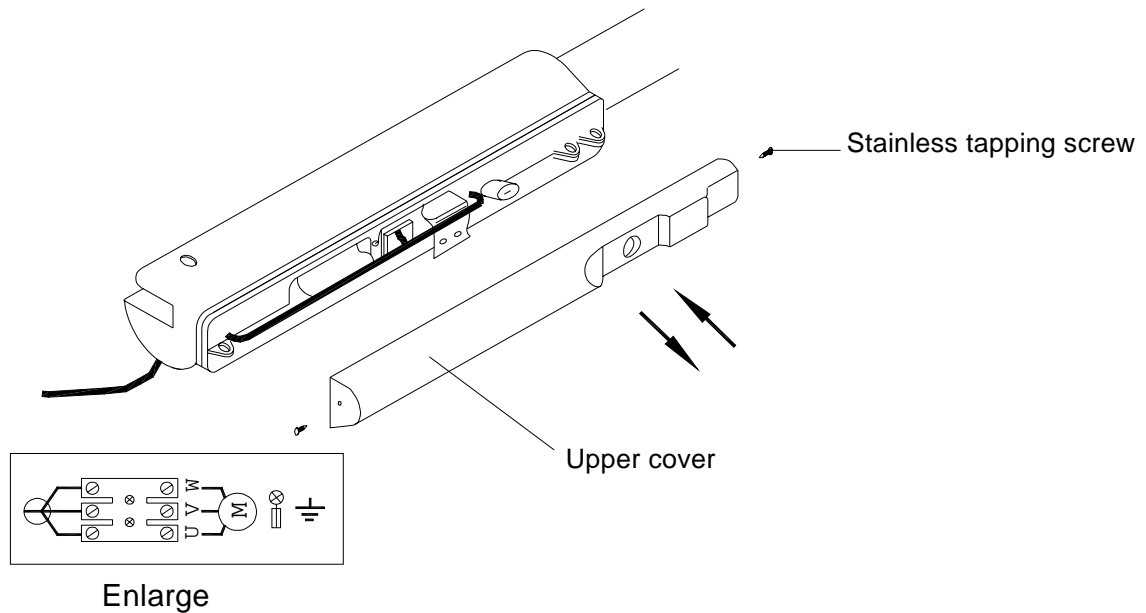

Hood Shield

Install the hood pipe, tighten the screws into the opener and cover the hood shield over the joint. See Fig. 9.

Fig. 9

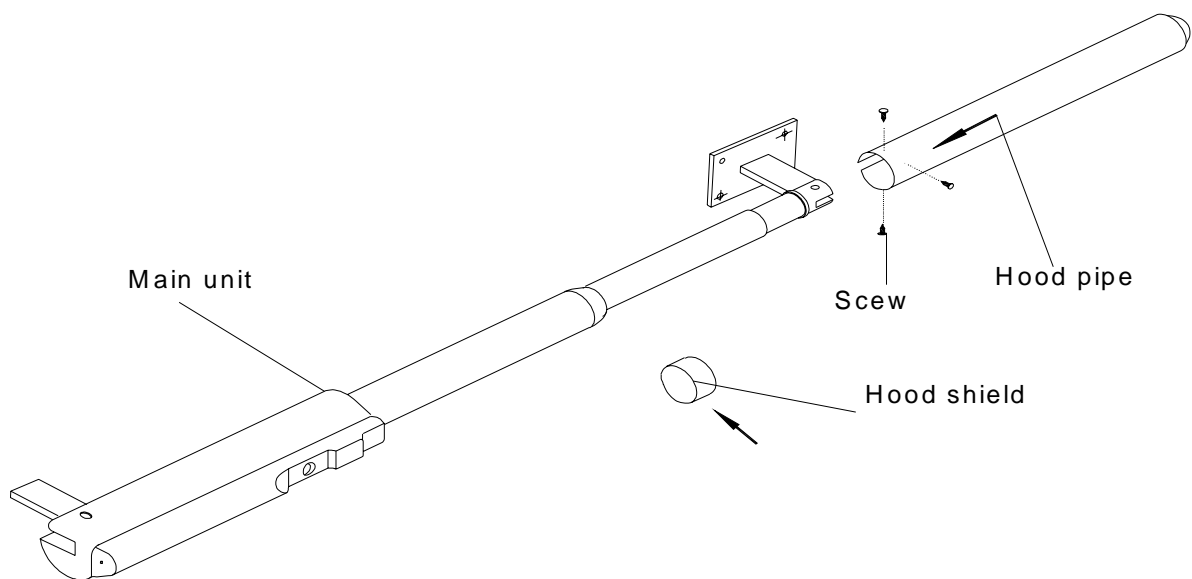

Waterproof caps

There are 8 caps in total – 4 to be used and 4 spares. When the gate opener is installed, the caps are used to cover the upper holes of the unit to avoid leakage. See Fig. 10.

Fig. 10

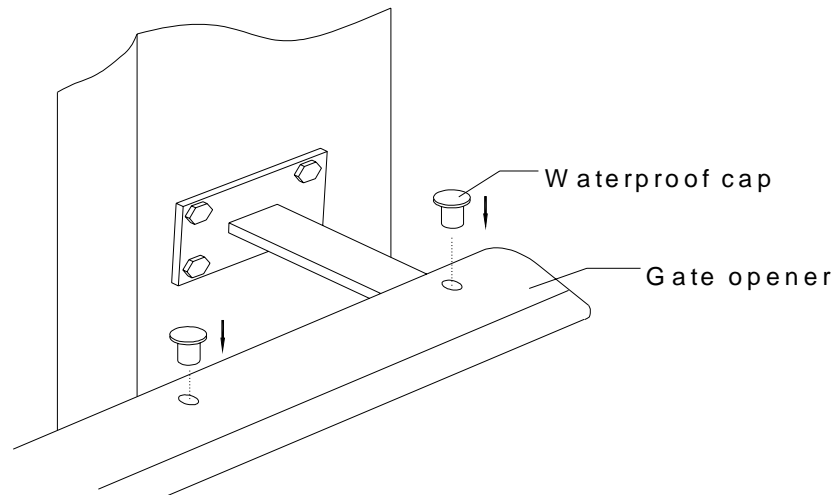

Retainer – Closed and Opened Positions

Close the gate section to its fully closed position; fix the retainer according to the position of the gate section. NOTE: Each section is completed separately. See Fig. 3.

If the maximum angle for installing is 105° , the retainer should be installed on the ground at approx. 100° . If the installing angle is 90° , the retainer should be installed at 90° . See Fig. 3.

Electric Lock

If the gate section is >5 feet (1.5 meters), it is recommended that you install the electric lock. Weld the steel plate of the lock to the gate, and then fix the lock. See Fig. 11 to determine the height of the plate.

Fig. 11

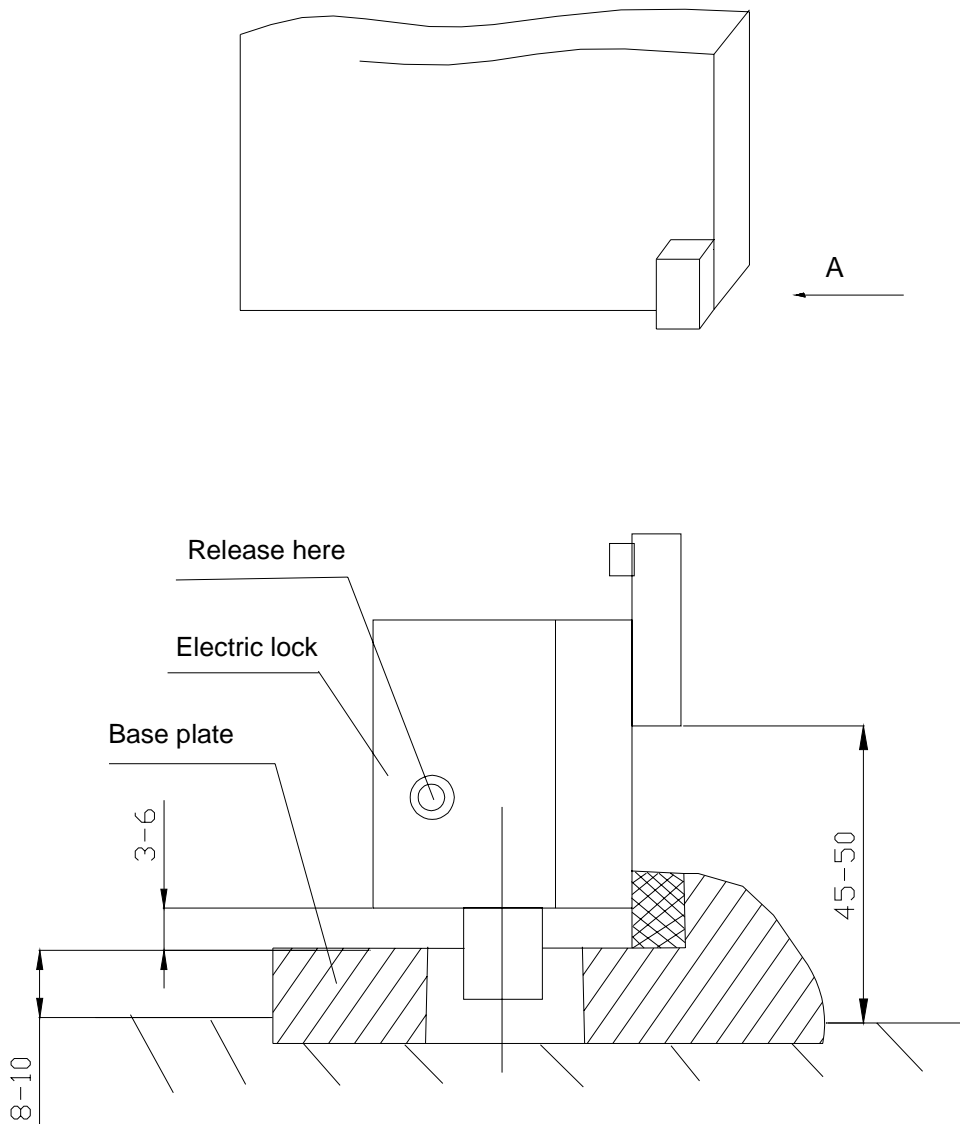

To install the base plate of the lock, fix the plate to the ground with 3 screws and make sure that the lock pin can fit tightly in the hole in the plate.

Adjustment

The pair of gate sections will not start simultaneously. The gate section without the lock will start to open earlier than the other gate section, so that both sections can be locked properly. A plate or tab can be welded on the gate section with the lock so that when it closes, it will trap the gate section without the lock between itself and the center stop block, thus locking both gate sections.

Mechanical Maintenance

- Check the screw lubricant and add #1 grease regularly to both gate actuators.
- Regularly verify that the gate swings freely and add grease as directed by the manufacturer of the gate.
- Keep opener clean at all times.

Electrical and Control Box Installation

1. Please Review the following Safety instructions before installation

Please read user's manual carefully and obey the following:

- *It should be installed by a qualified technician. Otherwise serious personal injury or property damage may occur.*
- *Before installation, all the locks of the gate should be unlocked.*
- *The auto-reverse function must be checked during installation to ensure that the gate can auto-reverse in event of obstruction.*
- *This auto-reverse function should be regularly inspected and adjusted, if necessary.*
- *When opening or closing the gate, do not attempt to walk or drive through the gate.*
- *Do not touch the gate while it is in operation.*
- *Please switch off before repairing it or opening its cover.*
- *Please erase and reset the code after installing the operator.*
- ***Before powering up the opener for the first time, verify that the force adjustment knobs are in a low position (turned towards counter clockwise direction) until the force adjustment is set in that section.***

2. Installation

(1) Install the cable

- In order to protect the wires, between the gate operator and the control box, armored cable, galvanized cable or PVC pipe must be set into the concrete when it is poured. Wires within the cable shall be located or protected so that no damage can result from contact with any rough or sharp part. The diameter of the cable should be more than 20mm²; the diameter of wire inside the cable should be more than 1.0mm². Gauge 16-3 wire or better is sufficient to wire the control box and the gate actuators.

(2) Install the control box

- The control box circuit should be equipped with single-phase breaker (10A).
- Make sure that power is OFF before making any electrical connections.
- Open the cover of the control box, remove the control board, and fix the control box on the wall. See Fig. E-1
- Perform the wiring and replace the cover. (See table 2 and Fig. E-3)

Note: (1) we regard the gate with the electrical lock as No.1 gate, the other gate as No.2 gate. (2) If you want to use auto-close function, the gate operator must be equipped with the infrared device.

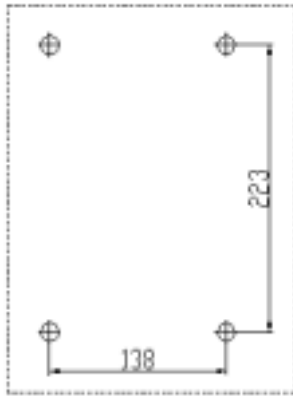

Fig. E-1 mounting size

Table 2 wiring between control box and gate operator

| Position | Tab | Remark |
|-------------------|------------|------------------------------|
| 21(Terminal X12) | L | Connect live wire |
| 21(Terminal X12) | N | Connect neutral wire |
| 21(Terminal X12) | E | Connect ground wire |
| 19 (Terminal X11) | U1 | Connect No.1 motor COM/U |
| 19 (Terminal X11) | V1 | Connect No.1 motor V |
| 19 (Terminal X11) | W1 | Connect No.1 motor W |
| 19 (Terminal X11) | C1, C1 | Connect No.1 motor capacitor |
| 18(Terminal X10) | U2 | Connect No.2 motor COM/U |
| 18(Terminal X10) | V2 | Connect No.2 motor V |
| 18(Terminal X10) | W2 | Connect No.2 motor W |
| 18(Terminal X10) | C2, C2 | Connect No.2 motor capacitor |
| 17(Terminal X9) | LAMP | Connect alarm lamp |
| 16(Terminal X8) | LOCK | Connect electronic lock |

(3) Install the External Keypad/Button Switch

The YG-200 is equipped with an interface for an external switch or keypad. The interface type is a NO (Normally Open) momentary switch to ground. To activate the opener, the keypad or other device must short the ground and the appropriate terminal momentarily. This type of switch is very common. To install the keypad attach one lead of your keypad to the O/S/C terminal and the other to the GND terminal. The keypad will function in single channel mode just like the RF remote. For three button switch installation, use the terminals for multi-channel mode. Three-button mode: The port 'GND' is the common port, the port 'OP' is used to open the gate, 'CL' is used to close the gate, and 'ST' is used to stop the gate. Single-button mode: connect two wires of button switch to 'O/S/C' (see Fig.E-3 terminal X7 No.15) of control board.

Safe guard (Infrared device)

If the infrared beam is broken during closing, the gates will reverse and open immediately. During opening, the beeper will ring. The control box is not factory equipped with an infrared device.

Connect signal wire of infrared device to 'IR' (see Fig. E-3 terminal X6, No.14), connect common wire (i.e. 'power supply -') of infrared device to 'GND' (terminal X6, No.14), and connect 'power supply +' of infrared device to '12V' (terminal X6, No.14).

The infrared device can be obtained through your dealer. To find a dealer in North American, go to www.gatekeeperltd.com/dealers

3. RF Remote

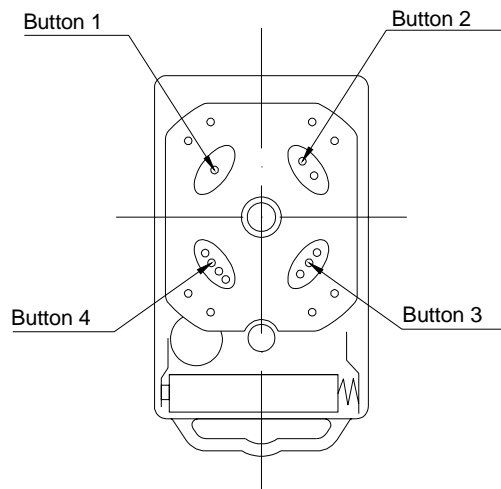

Fig. E-2

(1) Learn / erase remote controls

Verify that the force adjustments knobs are in the low position before proceeding.

Adding extra remote controls (Learn): Press red button on the control board (see Fig. E-3 No.12), then the 'LED' (see Fig. E-3 No.11) will be on, it will turn off when you press any remote control button. Press the same button, the 'LED' will flash at 2Hz frequency and then turn off; this indicates the learning process is finished. If it fails to set, the 'LED' will turn off automatically after flashing for 1 second, you should follow the steps above to reset.

Up to 25 remote controls may be used.

To erase all remote controls: press and hold the red button on the control board until 'LED' turns on and then turns off. This indicates that all the remote controls have been erased completely. You should reprogram the remote control if you want to control this operator (see **Adding extra remote controls** section).

(2) The remote control works in a single channel mode. It has four buttons. See Fig. E-2. With each press of the remote control button which has been programmed, the gate will close, stop, open or stop cycle.

Warning: Notify the users that the gate is never to be operated unless it is in full view.

Additional RF Remote controls can be obtained through your dealer. To find a dealer in North American, go to www.gatekeeperltd.com/dealers

4. Operation of the gates

The gates can be controlled by using remote control, single-button mode or three-button mode external button switch.

- Unlock the gate opener with the key. Push the gates to the opened (retracted) position manually. Lock the gate opener with the key.
- Turn the power on.
- Close the gates by using the remote control, single-button mode or three-button mode external button switch. The No.2 gate-leaf will close first, and then the No.1 gate-leaf with lock will close after 3 seconds.
- The gates will stop at the closed position automatically, or you can stop the gates at the closed position by remote control, single-button mode or three-button mode external button switch. If gates do not stop or bind before stopping, verify that the stop is firmly in place, and the force adjustment knob for that gate on the control board is adjusted correctly. Adjust counter-clockwise to reduce binding.
- Open the gates by remote control, single-button mode or three-button mode external button switch. First, the electrical lock will be opened, the No.1 gate-leaf with lock will open, and then the No.2 gate-leaf will open after 3 seconds.
- The gates will stop at the opened position automatically, or you can stop the gates at the opened position by remote control, single-button mode or three-button mode external button switch. If gates do not stop or bind before stopping, verify that the stop is firmly in place, and the force adjustment knob for that gate on the control board is adjusted correctly. Adjust counter-clockwise to reduce binding.
- Total working time: 21 seconds.

Note: The gate will return to open if you press the 'OPEN' button on the three-button mode external button switch during closing, the beeper will ring. We call this **Open priority**.

Auto-reverse function

It is very important that you tune the safety reverse function on your gate opener. Power the control box if it is not already and verify that you have completed the remote programming exercise. When properly adjusted, the gate should close and stop when it hits the stop block without overly forcing the gate, and reverse if it strikes an object before it reaches its stop. An alarm should sound if it activates the auto reverse. Use a screw driver to rotate the Force Adj. knob. Rotating clockwise will increase the resistance needed to trip the safety reverse function. Rotating counter-clockwise will decrease the resistance. If the gate does not move when activated, or auto reverses without striking an obstacle, then the resistance setting may be too little. If the gate does not stop when an obstruction is placed in its path, then the setting may be too high. Start with just above the minimum value, and tune it to use the minimum setting for which the gate will function.

WARNING: Do not attempt to tune the gate by placing your hand, arm or other body part in the path of the gate, serious injury could result. Also placing a heavy immovable object in the path to test with could cause damage to the gate opener motors. Instead, place a light object in the path, preferably something like a chair or trash can which will be pushed out of the way if the setting is still too high without causing damage to the gate motors. Note, this auto reverse function should be regularly inspected and adjusted if necessary. Once this step is complete replace the cover and install the rubber caps over the screws.

Auto-close function

Turn the fourth dip-switch (See Fig. E-3 No.13) to the ON position; the gates will stay open for 30 ± 3 seconds before automatically closing. Factory preset: the fourth dip-switch is in the OFF position, i.e. the auto-close function is shut off. An Infrared device is required to be installed for safety if the auto-close feature is enabled.

Safe guard (Infrared device)

If the infrared beam is broken during closing, the gates will reverse and open immediately.

During opening, the beeper will ring. The control box is not factory equipped with an infrared device.

The infrared device can be obtained through your dealer. To find a dealer in North American, go to www.gatekeeperltd.com/dealers

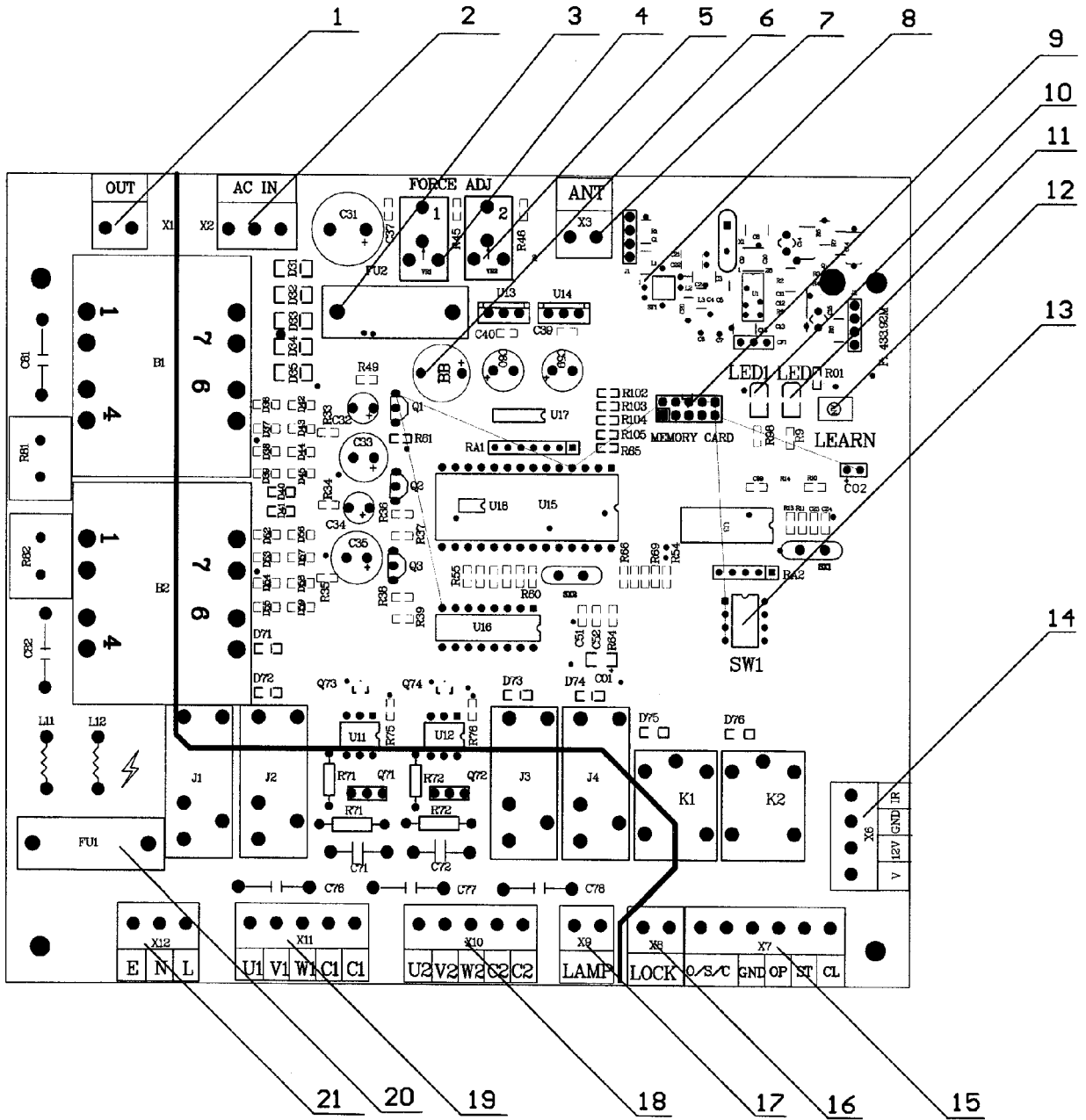

Fig. E-3 Control board

Table 3 wiring notes of control board

| <i>Position</i> | <i>Function</i> | <i>Remark</i> |
|-----------------|---|---|
| 1 | <i>Transformer input</i> | <i>AC110V</i> |
| 2 | <i>Transformer output</i> | <i>AC12V</i> |
| 3 | <i>Fuse</i> | <i>5 x 20 2A</i> |
| 4 | <i>Force adjustor (for No.1 gate-leaf with electrical lock)</i> | <i>The resistance may be increased or decreased by rotating clockwise or anticlockwise.</i> |
| 5 | <i>Force adjustor (for No.2 gate-leaf)</i> | <i>The resistance may be increased or decreased by rotating clockwise or anticlockwise.</i> |
| 6 | <i>Beeper</i> | <i>12V</i> |
| 7 | <i>Antenna</i> | <i>Impedance: 50Ω</i> |
| 8 | <i>Receiver panel</i> | <i>Receive signals</i> |
| 9 | <i>Memory card</i> | <i>It can be unplugged; it is used to store signals.</i> |
| 10 | <i>Power indicator light (LED1)</i> | <i>1206 green</i> |
| 11 | <i>Indicator light (LED)</i> | <i>1206 red</i> |
| 12 | <i>Learn button</i> | <i>6 x 6 red</i> |
| 13 | <i>Dip-switch</i> | <i>Set auto-close function</i> |
| 14 | <i>External device interface</i> | <i>Connect infrared device</i> |
| 15 | <i>External button switch interface</i> | <i>Connect external button switch</i> |
| 16 | <i>Electrical lock interface</i> | <i>DC12V</i> |
| 17 | <i>Alarm lamp interface</i> | <i>AC110V</i> |
| 18 | <i>Motor and Capacitor interface</i> | <i>Connect No 2 motor</i> |
| 19 | <i>Motor and Capacitor interface</i> | <i>Connect No 1 motor</i> |
| 20 | <i>Fuse</i> | <i>5 x 20 10A</i> |
| 21 | <i>Power supply</i> | <i>AC110V 60Hz</i> |

Table 4 Troubleshooting

| Symptoms | Possible cause | Remedy |
|--|--|--|
| Gate will not open or close | (1) Power is OFF. (2) The gate is obstructed. (3) Force Adj. Is set too low. | (1) Make sure that power is ON. (2) Remove obstructions. (3) Rotate force adjustment knob clockwise |
| Gate fails to reverse. | (1) The 'FORCE ADJ' is adjusted too high. | (1) Adjust 'FORCE ADJ' counter-clockwise to decrease force. |
| Gate begins to close, then reverses. | (1) The 'FORCE ADJ' is adjusted too low. (2) The gate is obstructed. | (1) Adjust 'FORCE ADJ' clockwise to increase force. (2) Remove obstructions. |
| Remote control does not work | (1) The indicator light of remote control does not light. (2) Remote control is not suitable for receiver. (3) Receiver panel. | (1) Battery level may be low, replace the battery inside the remote control. (2) After making sure the codes are correct, erase remote controls and then re-program the remote control. (3) Check the receiver panel; make sure it is plugged in at the control board. |
| Gate running direction is not correct, or gates run in different directions. | (1) Wiring is incorrect. | (1) Please change wires "V1 and W1" or "V2 and W2". If the wiring between two gates is wrong and the gates cannot work, please check the wiring between "U1, V1, W1" and "U2, V2, W2". |
| Gate does not stop when it should or closes too hard | (1) The 'FORCE ADJ' is adjusted too high. (2) Positive stops are not installed properly or are installed too far from the opener's limit of travel. | (1) Adjust 'FORCE ADJ' anticlockwise to decrease force. (2) Install positive stops as described in the mechanical positive stop installation section of this manual or move stop in closer to the opener's limit of travel. |
| Gate does not open far enough or does not have the proper opening angle | The gate opener is not installed properly according to fig. 3 in the gate geometry section of this manual. | Either modify the installation to meet fig. 3 or adjust the size or replace the installation brackets in accordance with the gate geometry section of this manual. |

Gatekeeper Ltd. Limited Warranty

Gatekeeper Ltd. warrants the YG-200 Swinging Gate Opener to be free of defects in materials and workmanship for a period of 1 year from the date of purchase subject to certain limitations.

This warranty shall not apply in the following circumstances, misuse, vandalism, accident, neglect, unauthorized repair or modification, acts of God (lightning, flood, insect damage etc.), power surge, corrosive environments, incorrect installation or application, damage to mechanism due to wrong type of gate, incorrect weight, gate not operating freely or not on level ground etc.

The warranty set forth here shall be entirely exclusive and no other warranty, either written or oral is expressed or implied. Gatekeeper Ltd specifically disclaims any and all implied warranties of merchantability or fitness for a particular purpose. It is the purchaser's sole and exclusive responsibility to determine whether or not the equipment will be suitable for a particular purpose. In no event shall Gatekeeper Ltd be held liable for direct, indirect, incidental, special, or consequential damages or loss of profits whether based on contract, tort, or any other legal theory during the course of the warranty or at any time thereafter. The installer, purchaser and/or end user do agree to assume all responsibility for all liability in use of this product, releasing Gatekeeper Ltd of all liability.

For service under this warranty, please contact your dealer. All parts, accessories, service and support for Gatekeeper products is supplied through our network of dealers. Dealer information can be obtained at www.gatekeeperltd.com/dealers

**** Special Warranty Note:**

Improper installation of the YG-200 can cause the actuator arms to overrun and unscrew into two parts. This can sometimes cause damage to parts 9 or 10. Carefully read and apply the directions in this manual to prevent this. However if this condition does occur, do not panic. The operator can be easily reassembled by inserting part 4 into the rest of the assembly and rotating clockwise. Since this condition is due to improper installation, this will not be considered an in warranty repair. However if any parts were damaged due to this condition, parts can be obtained from your dealer. To find a dealer visit: www.gatekeeperltd.com/dealers

Gatekeeper Ltd.
P.O. Box 752
Laceys Spring, AL 35754
info@gatekeeperltd.com

For updated versions of the manual see:

<http://www.gatekeeperltd.com>

*For Additional Remotes, Infrared Photo Cells or
Parts please contact your dealer. To locate a
dealer, please visit us at:*

www.gatekeeperltd.com/dealers